

LIFTKET

ELECTRIC CHAIN HOIST

eepos
Cranes

Official partner for Liftket hoists Pan-India



Contact

+91 744 740 9715
info@eposcranes.co.in

LIFTKET STAR

125 - 2.000 KG

S W L	ISO / FEM	Lifting speed [m/min]		Type		Chain [mm]	ED [%]	Switches [S/h]	Power [kW]		Weight [kg]	Dimensions [mm]							Hook dimension DIN 15401
		50 Hz	60 Hz						50 Hz	60 Hz		HH=3m; AÖ	A	B	C	G	G2	ø N	
125	M7 / 4m	8	9,6	030/62	1/1	5,2x15	60	360	0,55	0,65	18	212	192	220	380	406	25	20	012
125	M7 / 4m	8/2	9,6/2,4	031/53	1/1	5,2x15	60/40	360	0,32/0,08	0,38/0,1	18	212	192	220	380	406	25	20	012
250	M7 / 4m	4	4,8	030/65	1/1	5,2x15	60	360	0,37	0,44	18	212	192	220	380	406	25	20	012
250	M6 / 3m	8	9,6	030/64	1/1	5,2x15	50	300	0,55	0,65	18	212	192	220	380	406	25	20	012
250	M6 / 3m	8/2	9,6/2,4	031/51	1/1	5,2x15	50/25	300	0,32/0,08	0,38/0,1	18	212	192	220	380	406	25	20	012
250	M5 / 2m	12	14,4	030/50	1/1	5,2x15	60	240	0,55	0,65	18	212	192	220	380	406	25	20	012
250	M6 / 3m	12/3	14,4/3,6	051/52	1/1	5,2x15	40/25	240	0,55/0,12	0,66/0,14	33	266	232	274	388	436	35	20	012
250	M6 / 3m	18/4,5	21,6/5,4	051/55	1/1	5,2x15	60/25	240	0,9/0,2	1,1/0,24	33	266	232	274	388	436	35	20	012
250	M6 / 3m	24	28,8	050/52	1/1	5,2x15	60	240	1,1	1,3	33	266	232	274	388	436	35	20	012
500	M6 / 3m	4/1	4,8/1,2	031/51	2/1	5,2x15	50/25	300	0,32/0,08	0,38/0,1	21	212	192	220	428	454	25	22	025
500	M5 / 2m	8/2	9,6/2,4	071/54	1/1	7,2x21	60/25	240	0,9/0,2	1,1/0,24	42	266	232	274	413	460	35	22	025
500	M5 / 2m	10	12	070/51	1/1	7,2x21	60	240	1,1	1,3	36	266	232	274	413	460	35	22	025
500	M5 / 2m	10/2,5	12/3	071/53	1/1	7,2x21	60/25	240	0,9/0,2	1,1/0,24	42	266	232	274	413	460	35	22	025
1000	M5 / 2m	4/1	4,8/1,2	071/54	2/1	7,2x21	60/25	240	0,9/0,2	1,1/0,24	47	266	232	274	514	561	35	28	05
1000	M5 / 2m	6	7,2	070/55	1/1	7,2x21	40	240	1,1	1,3	36	266	232	274	413	460	35	22	025
1000	M5 / 2m	6/1,5	7,2/1,8	071/55	1/1	7,2x21	60/25	240	1,1/0,2	1,3/0,27	42	266	232	274	413	460	35	22	025
1000	M6 / 3m	8/2	9,6/2,4	091/51	1/1	9x27	60/25	240	1,8/0,45	2,16/0,54	67	359	283	359	513	548	40	28	05
1000	M6 / 3m	10/2,5	12/3	091/52	1/1	9x27	60/25	240	1,8/0,45	2,16/0,54	67	359	283	359	513	548	40	28	05
1600	M5 / 2m	4	4,8	070/54	2/1	7,2x21	60	240	1,1	1,3	41	266	232	274	514	561	35	28	05
1600	M5 / 2m	8	9,6	090/55	1/1	9x27	60	240	2,2	2,6	69	359	283	359	513	548	40	28	05
1600	M5 / 2m	8/2	9,6/2,4	091/55	1/1	9x27	60/25	240	3,0/0,75	3,6/0,9	88	359	283	359	513	548	40	28	05
1600	M5 / 2m	10/2,5	12/3	091/56	1/1	9x27	60/25	240	3,0/0,75	3,6/0,9	88	359	283	359	513	548	40	28	05
2000	M5 / 2m	3	3,6	070/55	2/1	7,2x21	40	240	1,1	1,3	41	266	232	274	514	561	35	28	05
2000	M5 / 2m	3/0,75	3,6/0,9	071/55	2/1	7,2x21	60/25	240	1,1/0,2	1,3/0,27	47	266	232	274	514	561	35	28	05
2000	M6 / 3m	4/1	4,8/1,2	091/51	2/1	9x27	60/25	240	1,8/0,45	2,16/0,54	76	359	283	359	620	655	40	30	1
2000	M6 / 3m	5/1,25	6/1,5	091/52	2/1	9x27	60/25	240	1,8/0,45	2,16/0,54	76	359	283	359	620	655	40	30	1
2000	M5 / 2m	8	9,6	110/54	1/1	11,3x31	60	240	4,0	4,8	90	359	291	367	611	678	50	30	1
2000	M5 / 2m	8/2	9,6/2,4	111/56	1/1	11,3x31	60/25	240	3,0/0,75	3,6/0,9	90	359	291	410	611	678	50	30	1

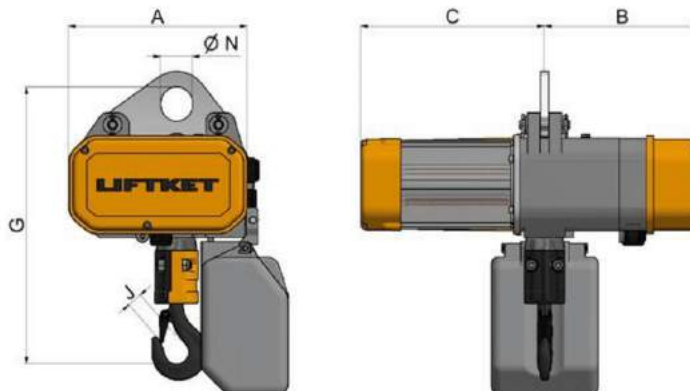



STATIONARY VERSION

- Stationary version with hook or eye
- Eye (connection between crane and trolley) compatible with all commercially available trolleys and suspensions



STAR VFD

- Load-dependent, infinitely variable control from 2 to 36 m/min
- Up to 200 % faster without load
- Easy-to-read display with operating hours, remaining service life according to FEM
- Brake cycles and starts



TROLLEYS // BOGIES

- Manual or electric trolleys in various designs for each steel section girder
- Short suspension and precise horizontally suspended hoist due to two-bolt suspension
- High-quality, galvanized impellers and fall protections



LIFTKET

ELECTRIC CHAIN HOIST

eepos
Cranes

Official partner for Liftket hoists Pan-India

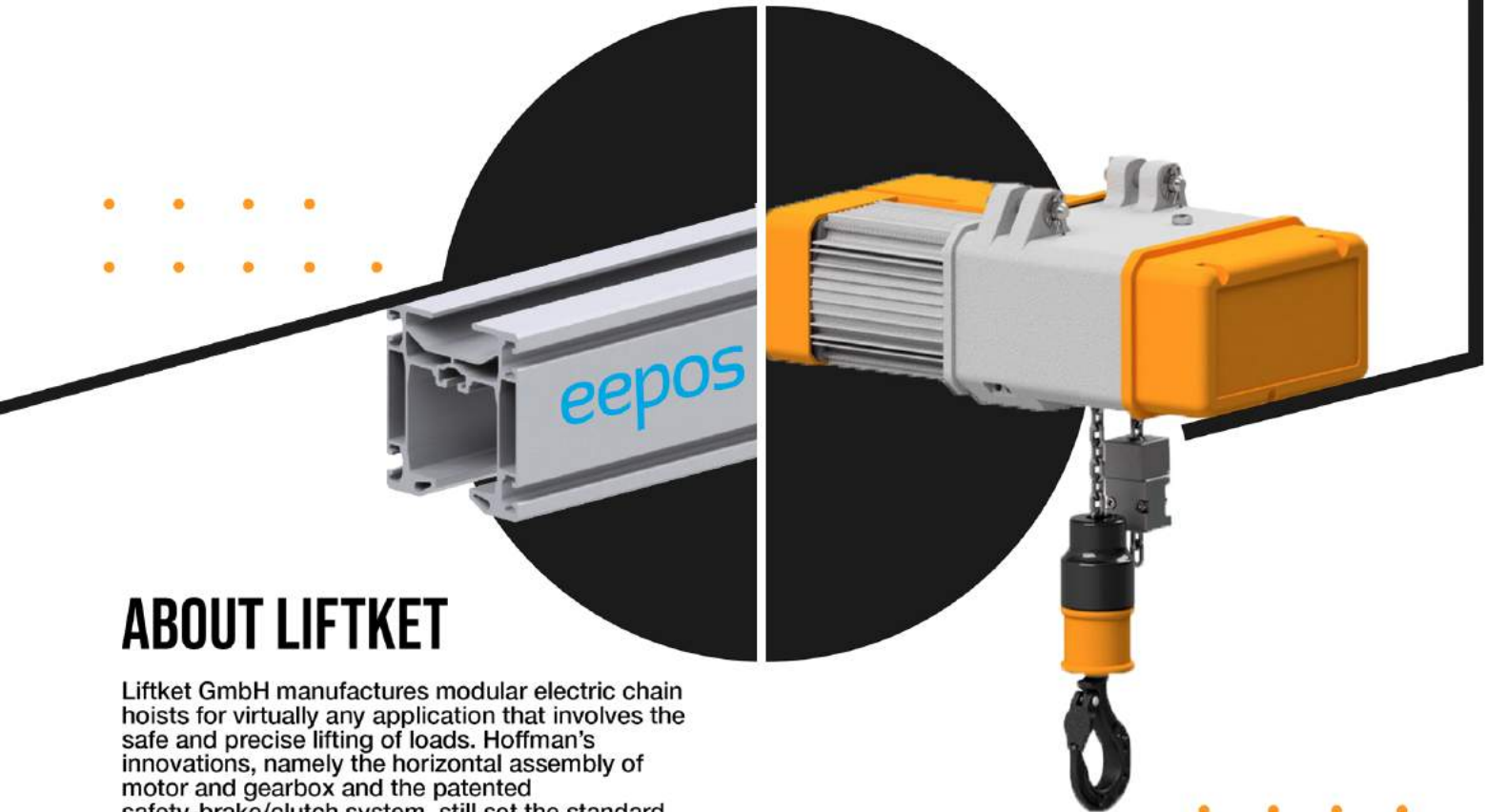

ABOUT LIFTKET

Liftket GmbH manufactures modular electric chain hoists for virtually any application that involves the safe and precise lifting of loads. Hoffman's innovations, namely the horizontal assembly of motor and gearbox and the patented safety-brake/clutch system, still set the standard for electric chain hoists.

WHY LIFTKET?

- Designed to withstand the rough environment with robust aluminium body
- Range of capacity from 125 KGs to 25000 KGs.
- Smooth and noiseless operation.
- Speeds available in single, double and VFD.
- Input power 380-415V, 50 Hz, IP 55
- With upper and lower limit switch.
- Lifting motor with thermal protection.

Contact

+91 744 740 9715
info@eposcranes.co.in

LIFTKET PRODUCTS

SPEED LINE HOISTS

Deliveries within 2-3 weeks ex-works

- All Models are made in germany
- 24 VAC low voltage control, operating voltage 3ph/380-415V/50Hz,
- With one hole suspension eye, hook suspension, hand or electro trolley
- Patented safety-clutch system
- First class materials, lifetime of parts exceeds all the requirements of FEM
- Extremely low maintenance
- Controls are very easy and efficient in maintainance.

